

Sports and Organization Rules of the International Judo Federation

Contents

1. Preamble
2. Basic principles
3. Calendar
4. Age Categories
5. Weight categories
6. Contest Duration
7. System of Competition
8. Entries
9. Application to hold Championships
10. Responsibility of the Organizer
11. Obligations of the IJF.
12. Obligations to be undertaken by the Organizing National Federation.
13. Organization
14. Control: **Judogis**, Back Identifications, Advertising and Marking
15. Draw
16. Weigh-in
17. Competition Venue
18. Standard requirements for Competition Area and **Tatamis**
19. Recommendations about Requirements for the Press
20. Officials (see check lists)
21. Opening and Awards Ceremonies
22. Medals, Diplomas and Awards Presentation
23. Other Provisions
24. Check lists
25. Standard forms for World championships
26. Annexes
 - * Annex 1. Regulations for Teams Championships
 - * Annex 2. Regulations for Specific Competitions
 - * Annex 3. Regulations and Recommendations concerning the Categories of Age and Weight
 - * Annex 4. Advertisement
 - * Annex 5. Marking authorized on **Judogi**
 - * Annex 6. Procedure of Appointment of the Technical Delegates
27. Copyrights

I. PREAMBLE

The Sport and Organization Rules (SOR) of the International Judo Federation (IJF) in conjunction with the Statutes, Finance Rules and the Refereeing Rules are the binding documents for the holding of World Championships and all competitions held under the responsibility and auspices of the IJF. Specific supplemental procedures will be issued for the holding of the Judo competitions at the Summer Olympic Games.

The SOR shall also serve as a guideline for the organization of all Judo competitions (on different levels: continental, national...). It is not allowed to depart from these Rules.

In the Sports and Organization Rules (SOR), the masculine gender used in relation to any physical person (for example, names such as member, leader, official, participant, competitor, athlete, judge, referee, personnel, or pronouns such as he, they, them) shall, unless there is a specific provision to the contrary, be understood as including the feminine gender.

Note: the IJF nominates Technical Delegates to control the Olympic Qualification Events and to advise the multi events organizers (See ANNEX 6)

The organization of the World Championships is the concern of the following bodies: the IJF, the Continental Union to which the Organizing National Judo Federation belongs and the National Judo Federation, which has been commissioned by a Congress with the hosting of the World Championships. The correspondent Continental Union is consulted in any questions and supports both bodies. The National Judo Federation must name an Organizing Committee to deal with the organization of the World Championships. The National Federation will in any case be responsible to the IJF Executive Committee for the proper holding of World Championships. The IJF has final appellate jurisdiction.

For each World Championships, an IJF Commission (IJF Organization Commission) will be appointed by the IJF Executive Committee (EC), which has the task to assist the Organizing National Judo Federation and to supervise the organization of the World Championships.

Any National Judo Federation hosting the World Championships is required to work out a proposal concerning its organization on the basis of the SOR and the local conditions. The IJF Executive Committee will support the Organizer by giving guidance, technical assistance and providing control.

The holding of World Championships and the work of the referees will be supervised by the IJF.

2. BASIC PRINCIPLES

The SOR is binding for all competitions held under the responsibility and the auspices of the IJF. It shall also serve as assistance and guideline for the organizers of national and other Judo competitions.

The official Refereeing Rules must be applied to and observed at all IJF competitions: Summer Olympic Games, World Championships, Continental Championships, and all IJF Tournaments.

Major Refereeing Rule's modifications can only be made by the decision of a Congress. These major modifications shall become valid only in the forthcoming quadrennial Olympic period.

Anyone organizing World Championships on behalf of the IJF and wishing to depart in any way from the SOR must obtain permission in writing from the IJF Executive Committee.

2.1 Allocation to the Organizers:

The Congress of the IJF shall allocate world Championships. In exceptional cases, the IJF Executive Committee may make such an allocation on behalf of the IJF Congress.

2.2 Control over regional Judo competitions:

The IJF shall accept the control over regional Judo competitions whenever this is so directed by the Executive Committee or the Congress. This requires, however, adherence to the Statutes, Finance Rules, SOR and Refereeing Rules. In such Judo competitions refereeing and technical organization should be dealt by the Continental Union or regional body and supervised by the officials nominated by the IJF for the event.

2.3 General Principle for Competitions:

The IJF recognizes men and women's competitions. Contests between men and women are not permitted.

2.4 Media rights:

The regulations covering television, radio, film, photographic and advertising rights are contained in the Statutes and Finance Rules.

3. CALENDAR

3.1 World Championships (for senior men and women) will be conducted in odd numbered years in accordance with the schedule (same monthly period) established for the Summer Olympic Games.

3.2 Junior World Championships (for men and women under 20) will take place in even numbered years in accordance with a schedule approved by the IJF Executive Committee.

3.3 Summer Olympic Games are held every four years in even numbered years in accordance with a schedule approved by the International Olympic Committee.

3.4 World Championships by Teams of Nations is held every four years (two years before the Summer Olympic Games) in accordance with a schedule approved by the IJF Executive Committee.

4. AGE GROUPS

World Championships (for senior men and women): no age limits.
Men and Women under 20, age limit is 19 years (calendar year).

Note: For the competitors who have not attained their majority, the National Federation should obtain authority from their parents.

5. WEIGHT CATEGORIES

The following weight categories will be utilized in the World Championships and competitions held under the auspices of the IJF for men and men under 20 years, for women and women under 20 years

5.1 Men and Men under 20 years (junior)

Extra-light weight	- up to and including 60 kg
Half-light weight	- over 60 kg up to and including 66 kg
Light weight	- over 66 kg up to and including 73 kg
Half-middle weight	- over 73 kg up to and including 81 kg
Middle weight	- over 81 kg up to and including 90 kg
Half-heavy weight	- over 90 kg up to and including 100 kg
Heavy weight	- over 100 kg

5.2 Women and Women under 20 years (junior)

Extra-light weight	- up to and including 48 kg
Half-light weight	- over 48 kg up to and including 52 kg
Light weight	- over 52 kg up to and including 57 kg
Half -middle weight	- over 57 kg up to and including 63 kg
Middle weight	- over 63 kg up to and including 70 kg
Half-heavy weight	- over 70 kg up to and including 78 kg
Heavy weight	- over 78 kg

5.3 Open Category:

The Open Category (no weight limit) will not be included in the Summer Olympic Games or in the Junior World Championships (for men and women under 20.)

Note: *Special recommendations for the weight categories and the age for **Youths**, boys and girls, are placed in annex n°3.*

6. TIME DURATION OF CONTESTS

Men & Women - Five minutes

Men under 20 years & Women under 20 years - Four minutes

Recommendations for:

'Youths', male and female (15/16 years old) - Three minutes

Note: any contestant is entitled to rest between contests for a period of 10 minutes.

7. SYSTEM OF COMPETITION

The System of Competition will be the elimination system with double repechage, i.e. for all categories the contestants will be divided into two tables by means of a draw, and an elimination system will be used to produce two finalists.

All competitors defeated by the group winners of A1, A2 (from table A), B1 and B2 (from table B) will take part in the repechage of their respective pools according to the elimination system. Their final contest will be against the loser of the final of each respective other table.

The winners (2) of those fights are placed 'third', the losers (2) are placed 'fifth'. The 'seventh' are the losers of the final repechage fights. (See appendix)

Note: *For Team Championships see in annex the regulations (annex N°1)*

8. ENTRIES

The participating National Federations must submit a preliminary entry (number of competitors) and a final entry (stating names, weight categories, placing at the Summer Olympic Games and World Championships) three months and, respectively, one month before the date of competition.

For the World Championships, the National Federations will be allowed, by the IJF during the official control of the registration, to replace one or several competitors by one or other competitors.

Note: The entries for the Open Categories must be confirmed or done the day before the competition for the Open Categories. Only the names of the competitors duly entered following the above procedure will be drawn. For the Men and Women World Championships and for the Junior World Championships (men and women under 20), the number of entries permitted is limited:

8.1 For the Senior Men and Women World Championships, each National Federation may enter one competitor in each of the weight categories, plus the open category, i.e. a total of 16 (7 categories plus the open category).

8.2 For the Junior World Championships (men and women under 20), each National Federation may enter one competitor in each of the weight category, i.e. a total of 14 (7 weight categories only, no open category).

8.3 Competitors may only be entered in the weight category to which they belong.

8.4 A competitor may not be entered in more than one weight category except for the Senior Men and Women World Championships in which he can be entered also in open category.

8.5 Competitors from three different countries must compete in a category in order for that category to be held in the Championships.

9. APPLICATION TO HOLD CHAMPIONSHIPS

Any National Federation, which is in good standing with the IJF, may apply to hold Championships. The application must be submitted in writing and should contain all data required by the Statutes, the Finance Rules, the SOR and the Refereeing Rules. (See Checklist)

The Organizing National Federation shall submit its application to hold the World Championships to the IJF General Secretary at least six months before the Congress held 4 years before the Event in case of Senior World Championships (it means for the Junior World Championships and the World Cup, 3 years before). Its Continental Union must approve the application.

After the World Championships has been allocated the Organizing Judo Federation shall deposit a guaranteed sum of 20,000 US dollars to the IJF (for the Senior World Championships). This sum will be used not only as a guarantee but also for charging the expenses of the IJF Inspection Team for the control of the installation and of the preparation of the Championships.

The sum minus the expenses mentioned above shall be returned to the Organizing National Federation by IJF whenever the championships have been achieved in accordance with the Statutes, the Finance Rules, the SOR, and the Refereeing Rules to the satisfaction of the IJF. Should the Organizing National Federation cancel the Championships, all or part of the deposit following a decision of the Congress may be forfeited to the IJF for the payment of costs incurred thus far. If the costs exceed the deposit, the IJF may claim these expenses from the Organizing National Federation.

9.1 TV Broadcasting Rights

Definitions:

a) International Signal: Is an international broadcasting signal consisting of pictures and sounds according to international TV standards through the use of multi-camera coverage in order to provide various camera angles and pictures.

b) Host Broadcaster: The company, which has purchased from the IJF or the IJF contracted agent, the right to televise the broadcast in the country in which the IJF Event is held.

c) Agent: The company(s) which purchased the TV broadcasting, advertising, and/or merchandising rights for the IJF Events from the IJF and which also holds the exclusive rights to sell these rights to third parties.

d) Broadcaster: The company(s) which has purchased the TV broadcasting right to a specific territory or country from the IJF or IJF contracted Agent.

e) Producer: The company, which produces the broadcasting signal consisting of pictures and sounds according to the international standard.

9.1.1 As a prerequisite for a National Federation to apply for the IJF Events, the Organizing National Federation must agree on the following conditions:

a) The Organizing National Federation shall supply International Signals, which are produced by the Producer or Host Broadcaster, consisting of pictures and sounds free of charge to the IJF or the IJF contracted agent. The quality of the signal must be an international signal consisting of pictures and sounds according to International TV standards from multi-camera coverage.

If the Producer who wishes to be Host Broadcaster desires to broadcast the program of the IJF Events as a host broadcaster within the organizing country, the IJF or the Agent should provide special considerations to the Organizing National Federation and the Producer.

b) If the Organizing National Federation cannot contract a Host Broadcaster and/or Producer and inform the IJF ten (10) months prior to the opening day of the IJF Events, the IJF may hold the right to cancel and rename the host Organizing National Federation at its discretion.

c) The minimum time requirement for supplying signals is to cover finals of the repechage, pool finals, semi finals, finals, and victory ceremonies for each category.

d) Those broadcasters, which have purchased the broadcasting rights from the IJF or IJF contracted agent, may have the broadcasting rights to that specific IJF Event until 31 December of the year in which the IJF Event was held.

9.1.2. When the Congress decides the Organizing National Federation of an IJF Event, the IJF will make the TV Broadcasting Contract with Agents or Broadcasters. Those Agents or Broadcasters have the exclusive TV Broadcasting Rights for a certain country or territory specified in the contract.

A National Federation applying for an IJF Event at the Congress should provide a guarantee (Letter of Intent) from a TV station or company that is willing to provide international signals according to the international standard free of charge to the IJF.

When the Agent sells the broadcasting rights to the Broadcasters, the Agent, is required to inform the IJF of all conditions concerning the negotiations and details of the contract. In addition, at the conclusion of an IJF Event, the Agent should provide the IJF with a detailed report including but not limited to financial terms of the contract with the broadcasters, broadcast times, viewer ratings, and any additional pertinent information.

The IJF shall inform the Organizing National Federation of the name of the IJF contracted agents upon signing of the contract.

10. RESPONSIBILITY OF THE ORGANIZER

The Organizing National Federation, in the person of the President of that Federation, shall be responsible to the IJF for strict adherence to the Statutes, the Finance Rules, the SOR, and the Refereeing Rules as well as for the good and proper conduct of the World Championships.

The contract between the IJF and the Organizers must be signed latest before the IJF Congress held 2 years before the Senior World Championships and for the Junior World Championships as well as the World Championships by Teams of Nations, 1 year before.

11. OBLIGATIONS OF THE IJF

11.1 The IJF will give support to the Organizing National Federation of the World Championships.

The IJF Organization Commission/IJF Inspection Team composed of the IJF Vice President of the concerned Continental Union, who in the absence of the IJF President will be the Chairman of the Commission, the General Secretary, the Sports Director, the Referee Director and by the General Treasurer of the IJF. The Commission is responsible to the Executive Committee for constant contact with the Organizing National Federation. It has to assist and to be available to this Federation for consultation and guidance. It has to submit as minimum two reports of the status of the organization to the Executive Committee.

- First report, six months before the previous Congress.
- Second report, one year before the championships.

The Executive Committee will hold a meeting at least six months prior to the World Championships, at which the host (National Federation/Organizing Committee) will be given an opportunity to discuss all matters pertaining to organization with the Executive Committee.

11.2 At least six months before the date the Organizing Committee of the National Federation of the World Championships, the IJF Executive Committee shall determine the number and kinds of meetings, the conditions required for these, and the officials attending them.

11.3 Six months before the date of the World Championships, the IJF Executive Committee shall fix the number of referees to officiate and the number of additional officials of the IJF to be invited for the duration of these World Championships.

11.4 The General Secretariat of the IJF at least six months prior to the World Championships shall send to the National Judo Federations official invitations, the provisional program, general comments on the organization, the regulations and the entry forms.

11.5 The General Treasurer of the IJF on the basis of the Statutes, Finance Rules and the SOR, shall prepare a contract covering all financial obligations for the organization of the World Championships.

12. OBLIGATIONS TO BE UNDERTAKEN BY THE ORGANIZING NATIONAL FEDERATION

12.1 Personnel and Equipment:

A National Federation staging the World Championships acts at the direction of the IJF and shall be fully responsible for the proper preparation of the Championships. On the basis of the SOR, it shall guarantee all necessary material and personnel conditions. The National Federation shall take all necessary action to provide insurance coverage against civil liability for the duration of the World Championships.

12.2 Congress and meetings:

When conducting the World Championships the National Federation shall also provide the necessary facilities to carry out a Congress of the IJF, meetings of the Continental Unions, of the Executive Committee, of the Sports Commission, of the Refereeing Commission, of the Education Commission, of the IJF. A Medical Symposium may be organized if the Executive Committee deems it advisable.

For the Congress of the IJF, the Organizer must ensure simultaneous translation in the official languages of the IJF (compulsory in English, French and Spanish).

12.3 Financial obligations:

The Organizing National Federation (Organizer) shall fulfill the financial obligations mentioned in the contract (cf. 11.5).

12.4 Transportation:

The Organizer must make available a means of transportation to facilitate the arrivals and departures of the officials and participants between the station or the airport and the place of accommodation, and also between the competition venue and training sites and the place of accommodation. These transportation arrangements are only made available to participants who stay in the official accommodation proposed by the Organizer.

A means of specific transportation must be provided for the duration of the event:

- dedicated cars for:
 - the President
 - the General Secretary and General Treasurer (dedicated car shared)
 - the Technical Delegates (dedicated car shared)
 - one car shared between the IJF Vice-Presidents (in addition to the minibus indicated below)

- minibus or buses for:
 - the IJF Vice- Presidents (one minibus)
 - the Sports Commission Members (one minibus)
 - the Referee Commission Members (one minibus)
 - the Education Commission Members (one minibus)
 - the referees designated by the Executive Committee of the IJF (bus(es))
 - the IJF Medical Commissioner, the IJF Media Commissioner and other officials designated by the Executive Committee of the IJF (minibus or bus).

12.5 Anti-doping control:

The Organizing National Federation shall take all necessary measures for carrying out the anti-doping control and for ensuring that the samples are analyzed at an internationally authorized laboratory recognized by the IOC and WADA. The control must be done according to the CODE, regulations of the Olympic Movement Anti-Doping Code, IOC and IJF. Three (3) competitors will have to undergo anti-doping test by weight category:

- the gold medallist,
- one of the three other medallists (by draw) and
- one of the four competitors placed 5th and 7th (by draw)

Note: for the two medallists involved the anti-doping control will be done just after the award ceremony of their weight category.

12.6 Gender Control:

After the finals a gender control will be done on the three female competitors nominated to undergo the anti-doping control. If a competitor nominated to undergo a gender control test and presents a certificate issued by an official institution or an authorized organization confirming her gender (e.g. IOC, Union's certificates), she is exempted of this control.

Note: The expenses related to the anti-doping control and gender control shall be borne by the National Federation organizing the World Championships.

12.7 Access to the Country of the Organizing National Federation:

The Organizing National Federation must guarantee via the responsible authority of its country that the IJF officials, the officials of the National Federations and the competitors wishing to take part in the World Championships will be given the appropriate credentials to enter and depart from its territory. The visas shall be valid for 30 days and be available 30 days before the date of the beginning of the World Championships. The National Federations must abide by the consular date limits.

12.8 General Program:

The National Federation organizing the World Championships shall work out on the basis of the SOR a detailed program containing all dates, activities and sites which are in any way connected with the World Championships to be organized. This program must be coordinated with the Organization Commission of the IJF at least six months before the date of the World Championships. The program shall be sent to each participating National Federation and to all officials of the IJF at least 30 days before the date of the beginning of the first activity. The program (updated) shall also be given to each National Federation and to the officials of the IJF upon arrival.

12.9 Accommodation:

The Organizer shall communicate to the National Federations the conditions for accommodation and meals at least three months before the date of the World Championships. The communication should contain information regarding the categories of the hotels (minimum three). In order to meet the needs of the National Federations, the hotels must be of a decent level.

13. ORGANIZATION

13.1 Information, Booklet and Reception Office:

During the Championships at least from the date of arrival of the first delegation up to and including the day that follows the last contest of the Championships, the Organizing Committee of the National Federation must set up for all participants a central office which shall be situated, in case of accommodation being provided at several hotels, at the contest site. This office shall provide all delegations with the information needed for the stay and the participation in the World Championships.

A representative should be present at the airport/station to welcome all delegations and provide information regarding further transportation.

The address and telephone number of the information and reception office shall be communicated to the National Federations and the officials of the IJF at least ten days prior to the Championships.

The office should be open 24 hours a day at least on the days of the arrival of the delegations.

13.2 Training:

The National Federation organizing the World Championships shall provide training areas and transportation for all delegations, which must correspond, to the number of competitors. Training hours should be coordinated with the delegations and included in a training timetable.

13.3 Control card system:

Preamble

Entries, NAME and Given name and IJF unique identification number (according to ORIS, Olympic Results Information System):

Names of the competitors have to be written in CAPITAL LETTERS followed by the Given name (s) in lower case letters; only the initial letter of the Given name (s) must be in CAPITAL LETTER.

For the IJF unique identification number the following format must be used:

JU CCC G DD MM YYYY SS

JU is for Judo,

CCC is representing the IOC NOC code, in which National Judo Federation registers a judoka,

G is representing Gender ("1" to be used for man, and "2" for woman),

DD MM YYYY is representing the athlete date of birth (in format-day, month, and year),

And **SS** is used as a sequence number (**01-99**) for the cases that more judokas of same gender, registered in same country, are born on the same date.

It will be National Judo Federations responsibility to assign this numbers correctly.

According to the entries of the competitors in the World Championships, the National Federations will receive "start-control cards" for the competitors listed on the entry forms. (Minimum three weeks in advance).

For the other members of the national delegations (coach, doctor, etc.) the Pass will be set up by the Organizing Committee of the Championships on the spot. (See point 20)

The National Federations are asked to fill in the "start-control cards", in capital letters or type written as describe below

13.3.1 Start-control Card and its use:

The card requires: Family NAME, Given name, country, date of birth, weight category, of the competitor and the signature of the responsible person of the National Federation.

The start-control cards will be utilized as follows:

Presenting the cards by the representatives of the National Federations during the "control of registration by nation". Only one representative must be personally present and submit the start-control cards duly completed for all competitors, as well as their identity documents (passport or official identity card).

After the control of registrations and signature by the IJF, the start-control card remains with the officials of the IJF for the draw, while the representative receives the Pass, which shall be signed by a representative of the Organizing Committee of the Championships.

13.3.2 Pass and its use:

Family NAME, Given name, country, date of birth, weight category, event and year.

The photograph of the competitor is to be fixed in the foreseen field of the Pass.

The signed Pass will be placed in a plastic bag facilitated for easy handling. During the official weigh-in each competitor has to submit his pass. The Pass is valid for duration of the Championships and represents for all controls the personal identity document of the competitor.

13.3.3 Nationality:

The competitors must be of the same nationality as the National Federation, which has entered them. Persons appointed by the Executive Committee of the IJF shall verify the citizenship of the competitors. The evidence of citizenship shall be production of a passport issued by the country for which the competitor is entered to compete.

In the following cases

a) where the competitions are being held in a country in which the residents do not hold passports while in that country;

b) where there is a possible problem of "joint citizenship", e.g. Dutch Antilles and the Netherlands an acceptable substitute for the passport will be a letter or certificate from the competitor's National Olympic Committee or, if there is no such body, from the National Sports Authority confirming the competitor's residence in that country and the citizenship.

If a competitor has multiple citizenships he may compete for only one country. A competitor who has represented one country in the Olympic Games, World Championships, in continental, regional games and/or Championships or International Tournaments organized by IJF or under its auspices, and who has changed his nationality or acquired a new nationality may participate to represent his new country provided that at least three years have passed since the competitor last represented his former country. If the two National Federations concerned agree they may request the International Judo Federation to shorten the period of three years, even to cancel the duration (see Olympic Charter, Rule 46 and the By-law to Rule 46). The competitor himself must come to the control. During the control the name, the age, the sex, the weight category for which the competitor has been entered, and the placing at the previous Olympic Games and World Championships shall be verified.

13.3.4 Insurance and civil liability:

Each National Federation is responsible for its competitors (the control of non pregnancy is placed under the responsibility of the National Federations as well the gender control) and must assume all responsibility for accident and health insurance as well as the civil liabilities for their competitors and officials, including the nominated referees, during the World Championships.

13.3.5 Anthems and Flags:

The Organizer must ensure that the chiefs of the delegations provide their countries' national anthems (short version) and national flags. (Size: 1,20 m x 1,80 m). In the event the Organizers provide the Anthems and Flags the chiefs must assure themselves of the accordance with their country of origin.

14. JUDOGIS, CONTROLS, BACK IDENTIFICATION, ADVERTISING AND MARKINGS

14.1 Control:

The competitors and their judogi shall be checked and found to be in accordance with the Refereeing Rules of the IJF and SOR requirements, (Article 3 - Judo uniform and Article 4 - Hygiene), prior to each contest.

Note: the blue color standards must be between the pantone numbers n° 18-4051 and n° 18-4039 on the pantone scale of TP or n° 285 or n° 286 on the pantone scale for print.

14.2 Back identification:

The back identification (Bibs) worn by the competitors shall be made from white material and meet the following:

- a) Dimensions: 30 cm x 30 cm
- b) Height of the figures: 11 cm (National Olympic Abbreviations)
- c) If an advertisement or publicity appears on the back identification, the letters composing it will not be more than 7 cm high spread on 30 cm length.

On the Bibs, possibility of indication of the competitors/champions (e.g. by use of different colors...)

Note: if requested the IJF may authorize the use of Bibs of 30 cm x 40 cm offering the possibility to place on this additional stripe the name of the competitor (12 letters maximum of 7th cm maximum high)

14.3 Advertising:

Publicity: Each National Federation has to make sure that the publicity (ies) placed on the judogi are in conformity with the rules of the IJF as defined in the SOR. Non conforming judogis will not be permitted to be utilized (see annex n° 4).

14.4 Acceptable Markings on the Judogi:

- a) National Olympic Abbreviation (see 14.2)
- b) National emblem (on left breast of jacket), maximum size 100 cm².
- c) One manufacturer's trademark (on bottom, left side of the jacket), maximum size 20 cm².
- d) One manufacturer's trademark (on bottom, in front of the left leg of the trouser), maximum size 20 cm².
- e) One manufacturer's trademark at one end of the belt, maximum size 20 cm².

Note: for the Summer Olympic Games as well as IJF Events the manufacturers trade mark allowed are 20 cm² from Athens 2004 Olympic Games.

f) Indication of the placing (1st, 2nd, 3rd) at the Olympic Games or World Championships, in an area of 6 cm x 10 cm on bottom, front of the left side of the jacket or by the use of different colors on the Bibs.

g) Name of the competitor can be placed (printed, embroidered in the back of the jacket) but in no case placed in a position to prevent an opponent from grasping the back of the jacket. The size of the letters is maximum 7cm high; length of the name is 30 cm maximum (a maximum of 12 letters or less is recommended). This rectangular area of 7 x 30 cm must be located at 3 cm under the collar of the jacket, the back identification must be fixed at 4 cm under this area (see annex n° 5).

15. DRAW

By Computer (or Manual if either agreed or requested by the IJF) with the use of the IJF software (or of other software if authorized by the IJF).

The draw for the positions on the contest system lists must be held on the day prior to the first competition by the Organizing Committee under the direction of the Sports Commission of the IJF. Special regulations exist for the Olympic Games.

The draw for the "open" category shall be made on the day prior the competition for that «category».

A maximum of two delegates per National Federation may attend the draw. The materials required for the draw shall be provided by the Organizing National Federation (see checklist).

The result of the draw (two sets) shall be distributed by the representatives of the Organizing National Federation to the representatives of each participating delegation immediately after it is finalized.

Drawing Procedure for World Championships and Olympic Games and others IJF events are under the control of the Sports Director assisted by the Sports Commission of the IJF.

The "four medal winners" (gold, silver and two bronze) of each category of the most recent World Championships or Olympic Games will be separated on the contest system list in a way which prevents them from competing against each other before the finals of table A and B.

15.1 Principle (for manual draw):

The draw is made by calling of the competitors' names from the official list and thereafter drawing a number and affixing the number to the contest system list.

15.1.1 Situation No. 1 (no seeding):

The quantity of numbers ping-pong ball bearing numbers corresponding to the number of competitors is put in a container or a sphere.

The names of the competitors are called from the official list; their numbers are drawn and affixed on the contest system list.

15.1.2 Situation No. 2 (two seedings):

a) It is determined which competitor will be in table "A" and which one will be in table "B". For this purpose, two Ping-Pong balls (one "A" and the other "B") are put in a container or a sphere; the first competitor of the list is called, the table is drawn. The second competitor will automatically be in the other table.

b) In order to determine the two seedings in the respective table, the following procedure will be utilized:

1) All odd numbers of table "A" are put in a container or a sphere.

2) The number of the competitor is drawn

The same procedure, utilizing the even numbers will be followed to ascertain the placing of the competitors for table 'B'.

The remaining numbers (corresponding to the quantity of competitors entered in the category) are put in a container or a sphere. The names of the competitors are called on the official list and their numbers are drawn and affixed to the contest system list.

15.1.3 Situation No 3 (three seedings):

a) If the first place winner does not compete, the second place winner is placed by draw in one table and the two third place winners in the other table by draw.

b) If the second place winner does not compete, the first place winner is placed by draw in one table and the two third place winners in the other table by draw.

c) If one of the third place winners does not compete, the first place winner will be placed in one table and the second and the remaining third place winner in the other table.

15.1.4 Situation No 4 (four seedings):

First the finalists must be placed by draw in the different tables, and after the two third place winners are placed by draw in the remaining groups of the tables.

The Organizers shall make sure that the officials conducting the draw have the tables duly completed within the 30 minutes following the end of the draw.

Necessary equipment for the manual draw is:

a) 4 spheres or 4 containers of sufficient size

b) a small table on which to place 64 Ping-Pong balls bearing numbers from 1 to 64.

c) 2 Ping-Pong balls:

-One with the inscription "A"

-The other with the inscription "B"

d) 4 Ping-Pong balls:

-One with the inscription "A1"

-One with the inscription "A2"

- One with the inscription "B1"
- One with the inscription "B2"
- e) 14-contest system lists for 32 competitors
- f) 14 contest system lists for 64 competitors
- g) Plaques for the competitors on which will appear in characters of sufficient size: The back identification, the family name, first name and the nationality of the competitor.

Note: The contest system lists and the printing on these lists will be big enough to be seen by everyone in a room occupied by about 250/300 individuals. The lists will be placed on a wooden or metal board on legs. A system must be utilized which will permit placing easily the plaques on which will be written the names of the competitors (magnetic system, sticking, hooks etc.).

15. 2 Seeding for the World Championships by Team of Nations:

15.2.1 The seeding will take into consideration the results of the team individual members present based on the previous world championships.

15.2.2 Teams of the same Union must be separated to a maximum when possible, taking into consideration the ranking in the Union.

16. WEIGH-IN

For World Championships and Olympic Games and all events of the IJF or other events held under IJF auspices, **separate rooms for men and women must be available for the unofficial and official weigh-in.**

16.1 Responsibility:

Control of the weigh-in shall be the responsibility of the Sports Director and the Refereeing Director of the IJF.

16.2 Weigh-in times:

Official weigh-in for each category shall take place on the same day as competition in that category.

Official weigh-in control period shall be of one-hour duration and will commence at least, two hours before the scheduled starting time for the competitions.

Competitors shall be allowed to check their weight on the official weigh-in scales (that will be used for the official weigh-in) during the 1 hour before the official weigh-in commences.

There is no limit to the number of times each athlete may check his weight during this time of the unofficial weigh in.

16.3 Official Weigh-in Procedure:

- a) Each competitor shall bring to the weigh-in his Pass issued for the Championships .The competitor shall present the Pass to the official, who will verify identity of the competitor.
- b) The competitor shall weigh-in wearing only gymnastic underclothing or naked, under the supervision of a weigh-in official; the competitor may be requested to remove his underclothing to ensure he reaches the minimum weight limit of the weight category in which he is entered.
- c) The official supervising the weigh-in shall note and record the athlete's weight in kilograms (accurate to one decimal point of a kilogram). No tolerance shall be allowed either above or below the weight category.
- d) Only one weight control shall be permitted to each athlete upon the scales during the official weigh-in period.

16.4 Control for the competitors entered in the Open Category:

All competitors for the Open Categories must officially weigh-in at the prescribed time, the day of this precise competition.

16.5 Failure to appear for Weigh-in Control:

Should a competitor fail to appear for weigh-in during the official weigh-in period, this shall be noted beside his name on the official weigh-in list. The notation shall be signed by a weigh-in official and a member of the Sports Commission or of the Referee Commission.

The competitor will be excluded from competing in that weight category.

16.6 Failure to weigh within the prescribed limits of a category:

Should a competitor weigh either above or below the prescribed limits for the category in which he is entered; the exact weight shall be recorded in the normal manner. The weight shall be circled and signed by a weigh-in official, and a member of the Sports Commission or of the Referee Commission and by the athlete himself or a member of his delegation.

The athlete shall be excluded from competing in that weight category.

16.7 Failure to comply with official directions or with requirements of the SOR:

If at any stage during the weigh-in period, a competitor fails to comply with the directions of any weigh-in official or a member of the Sports Commission, or of the Referee Commission, or fails to comply with the requirements of the SOR, the competitor shall be prevented from participating in the weigh-in and the nature of the infraction brought immediately to the attention of the Sports Director and the Refereeing Director of the IJF.

16.8 Protection of privacy:

To protect the privacy of the competitors, officials supervising the weigh-in shall be of the same sex as the competitors.

The Organizers of the Championships shall make available a minimum of eight (among them 4 women) officials on each day of the weigh-in to assist members of the Sports Commission and of the Refereeing Commission.

Where no such official is available, scrutineers who are the same sex, as the competitors shall be appointed, subject to the approval of the Sports Director and the Refereeing Director of the IJF.

The Organizers shall also make available to the members of the Sport and Refereeing Commissions conducting the weigh-in, four copies of the weigh-in list for each weight category before the scheduled start of the official weigh-in period.

17. COMPETITION VENUE

The competition venue shall be of a representative character and be sufficiently large to hold the required competition areas and shall have a seating capacity of at least 8.000 - 10.000 spectators for the Senior World Championships. The competition areas shall be laid out in accordance with the SOR; section 18.1 and the Refereeing Rules, (Article 1).

The number of competition areas required for competition, four for the Senior World Championships, three for the Junior World Championships and the World Championships by Team of Nations. Special requirements shall be fixed in consultation with the Executive Committee of the IJF at least six months prior to Championships. The competition venue should have facilities for providing optimum audio-visual information to spectators and competitors (ongoing and following contests, names of referees for the contests and contest results).

The competition areas and the adjacent area shall be protected against the entry of unauthorized persons and there shall be a sufficient number of seats for the members of the Executive Committee of the IJF, the members of the Sports and the Refereeing Commissions and the Education Commission (for the Senior World Championships), the referees, the technical officials, the doctors as well as for first-aid personnel and assistants and the nominated officials of the IJF (about 70 persons).

A certain number of seats shall be reserved for guests of honor, Presidents and General Secretaries and heads of delegations of the participating National Federations, journalists and competitors and shall be marked as such. The seats for the competitors should be situated as close to the competition area as possible that enables direct access to the competition area.

17.1 Each competition area shall be equipped with two electronic scoreboards set up in the non-adjacent angles of the competition area and, as reserve, with manual indicating and recording devices, stopwatches, gongs, flags etc. which shall be provided by the Organizer in accordance with the Refereeing Rules.

17.2 The Organizer shall provide tables for at least sixteen people per competition areas (among them members of the Sports and Refereeing Commissions of the IJF). The officials at the table must be able to work independently of the other facilities. In addition to the tables for the competition areas there shall be a central table for the Jury (in charge of administration and discipline) and other appointed representatives, which shall be equipped with a microphone for central announcements.

17.3 There shall be two (2) tables for the doctors

17.4 There shall a table for judogi control per competition area.

17.5 Facilities should be available at the competition venue for a proper anti-doping control (separated for men and women) and gender control.

17.6 There must be warming up areas of minimum 400 square meters « attached » to the competition site or with the competition hall.

17.7 There must be a stand by area for the competitors controlled as close as possible of the contest mats. This stand by area should allow the competitors to watch and observe the contest before they have to go on the mat to compete

17.8 There must be dressing rooms capable of being locked, a first-aid room, massage benches, recreation rooms for the Executive Committee, the members of the Sports and Refereeing Commissions as well as the Education Commission members (for the Senior World Championships), the referees, a working room for the press, and lunchrooms.

17.9 Wireless microphones connected to the public address system must be available for use by referees. Provision shall be made for a duplicating system for information related to the competition.

17.10 Lighting of minimum 1500 lux up to 1800 lux shall be directed on to the competition areas from the top, in such a way that no shadows are caused and not from the sides or from an oblique angle. It must not handicap the activities the competitors, officials and spectators.

17.11 For other details concerning material and personnel requirements see checklists.

18. STANDARDS REQUIREMENTS FOR COMPETITION AREA (MAT) AND TATAMIS

18.1 Competition Area:

Each competition area shall be a minimum of 14 m x 14 m and a maximum of 16 m x 16 m and shall be covered by tatamis or similarly acceptable material, generally green in color which has been approved by the IJF.

The competition area shall be divided into two zones. The demarcation between these two zones shall be called the danger zone and shall be indicated by a colored area, generally red, approximately 1 m wide, forming part of the contest area, parallel to the four sides of the competition area.

The area within and including the danger zone, shall be called the contest area and shall always be of 8 m x 8 m to a maximum of 10 m x 10 m.

The area outside the danger zone shall be called the safety area and shall be at least 3 m wide.

An adhesive blue tape and a white tape, approximately 10 cm wide and 50 cm long shall be fixed on the center of the contest area at a distance of 4 m apart, to indicate the positions at which the contestants must start and end the contest. The blue tape shall be to the referee's right and the white to his left.

Where two or more adjoining competition areas are used, a common safety area of a minimum of 3 m is permitted.

A free zone, a minimum of 50 cm must be maintained around the entire competition area.

For the summer Olympic Games, World Championships, Continental Championships and IJF Tournaments, the contest areas will be 8 x 8 m each (with 3m of security around and 3 m minimum in between when two competition areas are adjacent).

Note: an electronic display with two color light bulbs will allow the co-ordination of the simultaneous arrival of the referees and the start of the contests on all mats at the beginning of the sessions (or any other display allowing this co-ordination).

18.2 Tatamis:

Today, generally measuring 1m x 2 m made of pressed straw or more frequently, from pressed foam. They must be firm under foot and have the ability of absorbing shock during "falls", covered with a elasticized material generally in red and other colors, blue, green and must not be slippery nor too rough. These elements making up the surface for the competition area must be aligned without space in between, be smooth on surface and fixed in such a way that they will not be displaced or move.

18.3 Changing Booth:

Booths allowing the competitors to change their Judogi (jacket, trousers) when they are requested to do so by the referees during the contests, have to be placed close to the competition areas.

18.4 Platform:

The competition area must be placed on a resilient floor or platform. This platform is optional but can be compulsory if it is so requested by the Executive Committee of the IJF and must be made of solid wood, while still having a certain resilience measuring approximately 18 meters on the side when there is only one competition area without ever going beyond 0.5 m (exception can be granted by the IJF under specific circumstances)

19. RECOMMENDATIONS ABOUT REQUIREMENTS FOR THE PRESS

The basic principle requirement for the press gallery shall be extra-territoriality, i.e. it must be inaccessible to any person (technicians, television teams of participating countries, and, above all, people from the public) without a press badge. Consequently, its entrance is to be secured by an official of the organizer. The press gallery, preferably situated in the center of the competition venue, in the middle between the two, three, or four competition areas, above and to one side there of shall provide, in the case of World Championships, between 140 and 200 seats (depending upon the country where the Championships is organized), all of the seats shall be equipped with shelves and wall-sockets. (This requirement is necessary for journalists using personal computers and laptops). At the best, where it is possible, those seats shall be equipped with television monitors; reporters and their technicians may take their seats if their lines are drawn accordingly. It will be most convenient,

however, to have them placed together with the TV and radio commentators, which then means to have a second zone to be secured.

Yet with a different arrangement, the area in front could be used by TV and broadcasting, the area in the rear being reserved for the writing press, could use the area in front. Thus, only one secured area is required.

As to the private telephone lines required, the press shall submit their applications to the appropriate supply source of the Organizing National Federations. The Organizing Committee shall not be involved. Those journalists who applied for private lines shall have priority on the press gallery. A working room with tables, chairs, wall-sockets shall be provided near the press gallery. Within this room, or when it is possible in another one, the telecommunication unit shall be installed under the auspices of a utility service selected of the Organizing National Federation. The basic structure of this unit shall, in the case of World Championships, consist of 12 telephone booths (either for cards or for coins), three facsimile sets and a teletypewriter. The Organizing Committee shall bear the costs for the installations of this telecommunication unit. The journalists shall pay for their private lines and for their communications.

Efficient and immediate result service shall be instituted; messengers to the press gallery will distribute the results of the competition. In order to assure an orderly distribution and use of the results they will be made available after each round in each weight category.

In the press center, there shall be 16 boxes, corresponding to the 16 categories (only 14 for junior), into which the results shall be fed continuously. At the end of the Championships, a complete survey of results shall be distributed to the journalists.

Two facilities are to be provided at which interview may be conducted.

- The first, a mixed zone as a meeting places for competitors just before they return either to the dressing rooms or training room, and journalists.
- Secondly an official zone with microphones and interpreters for interviewing the Medallists after the finals.

The photographers (for better identification they should be provided with a "special jacket") shall be placed as close as possible to the mat, on the same side as the TV cameras in order not to have the latter embarrassed by flashes. Between 60 to 90 places shall be provided for photographers (depending on the organizing country), without obstructions within their field of vision (no referees tables in front of them, no annoying passages). The minimum lighting for the mats shall be 1500 lux; however, 1800 lux would be better. In case an application has been made one or more darkrooms for development shall be provided, i.e. dark rooms (without openings) equipped with water supply and wall-sockets. The Organizing Committee shall be responsible for making such facilities available.

The press service of Championships shall be provided by a Press Officer to be designated by the Organizing Committee. It is recommended that the Press Officer be a journalist. In this case he cannot work for his newspaper. A representative of the International Sport Press Association and the IJF Media Commissioner will maintain liaison with the Organizers and the press officer in case of problems concerning professional duties and will assist the press officer in performing his duties, responsibilities and assignment.

20. OFFICIALS (see check-list)

20.1 IJF Officials:

Officials of the IJF shall be those persons appointed to that capacity by the Executive Committee of the IJF and who have to carry out functions connected with the championships on behalf of the IJF.

The officials of the IJF shall have special status and their identity cards shall be marked correspondingly. These identity cards authorize the officials to enter any area, which is in any way connected with the event.

20.2 IJF Referees:

The referees to officiate for the World Championships and the Summer Olympic Games will be appointed by the Executive Committee of the IJF following recommendations made by the Refereeing Commission at least six months prior to the date of the championships. It is necessary that all appointed referees have the permission of their National Federations to officiate during the World Championships and the Summer Olympic Games.

The referees selected by the IJF to participate in the Summer Olympic Games, World Championships and IJF Tournaments shall arrive in the hosting country 1 to 2 days in advance of the competitions depending on where they reside and leave one day after.

The referees shall wear the attire approved fixed by the Executive Committee of the IJF.

Prior to a contest the referees and judges should familiarize themselves with the sound of the gong or other signal, assure the proper condition of the competition area and the functioning of the scoreboard, and make sure that the judges' chairs are in the correct positions.

The referee must control the competitors (and ascertain) whether they comply with Article 3 and 4 of the Refereeing Rules. He shall ensure that there are no spectator, coach, photographer and other unauthorized persons in a position to influence or handicap the competitors.

The referee and the judges shall not be members of the same National Federations as the competitors at whose contest they are officiating and should not hold any official function, i.e. coach or manager.

20.3 Officials and Technical Assistants of the Organizing National Federation:

The timekeepers, list writers and recorders as well as other technical assistants must be of a minimum of 21 years of age, have a minimum of three years' experience as national referees and a good knowledge of the Refereeing Rules. The Organizing Committee must ensure that they have been thoroughly trained prior to officiating. There shall be a minimum of two timekeepers; one to register the real contest time and one to specialize in "osaekomi". If possible there should be a third person to supervise the two timekeepers to avoid any errors due to mistakes or forgetfulness.

For complete details see Refereeing Rules - Appendix article "Officials".

Assistants Responsible for Control

These assistants have several duties among which are checking the identity of the contestants, getting ready for the next contest, checking that the first contestant called is wearing a blue judogi and the second contestant called a white judogi, also checking the back identification of the fighters.

Those responsible for the judogi control must be familiar with Article 3 of the Refereeing Rules.

20.4 Medical Personnel:

The Organizing National Federation shall provide sufficient medical treatment during the competitions (one doctor per competition area). In addition to this an ambulance should be on stand-by for transporting injured competitors to a hospital. Arrangements must be made with a nearby hospital for emergency treatment.

20.5 Officials of the National Federations:

The Organizing Committee shall make available to each participating National Federation a free, specially marked spectator seat for the President or representative and, if there is a Congress held in conjunction with the event, a second such seat for another official person. Identity cards entitling their holders to enter the competition venue shall be given to each participating National Federation in accordance with the following modus:

- a) 1 - 2 competitors - two officials
- b) 3 - 4 competitors - three officials
- c) 5 - 6 competitors - four officials
- d) 7 - 8 competitors - five officials
- e) 9 - 10 competitors - six officials
- f) 11 - 12 competitors - seven officials
- g) 13 - 14 competitors - eight officials
- h) 15 - 16 competitors - nine officials

All National Federations shall have a doctor who is accredited to their delegation. If they do not have their own doctor, it may request that a doctor from another delegation be also accredited to its delegation. If neither of this alternative is available, a national federation must accept the doctor provided by the Organizing National Federation as their "accredited delegation doctor".

The heads of delegations, team managers, coaches, doctors and masseurs will be eligible to be recognized as officials.

21. OPENING AND AWARDS CEREMONIES

21.1. Preamble:

Judo Events are the property of the International Judo Federation, referred to hereinafter as the »IJF ", who shall delegate the organization to countries which candidacy to host the event and its ceremonies was approved by the IJF Congress. Countries organizing Judo Events have to put at the disposition of the IJF all the infrastructure and equipment necessary to a good holding of the event and the ceremonies.

21.2. Seating of IJF Officials:

IJF Officials shall be seated in the designated Officials area where the opening and closing ceremonies and medals' presentation take place. IJF Officials shall be seated in two or three rows in the designated Officials area. Shall be seated in the first row: local Government Representatives (Minister or other dignitary representing the supreme authority of the country hosting the event). This latter will have on his left the IJF President, and to his right the representative of the International Olympic Committee (or NOC).

The President of the National Olympic Committee shall be seated to the left of the IJF President.

The President of the National Federation organizing the event shall be seated to the left of the IJF President or his representative or at the left of the NOC President if he is present.

Shall be seated in the 2nd row: IJF Officials (Vice Presidents, Honorary Presidents, General Secretary, General Treasurer, Sports Director, Referee Director, Education Director, Media Commissioner, Medical Commissioner, and Olympic Commissioner).

Shall be seated in the 3rd row: local VIP guests, sponsors' representatives, spouses of IJF Officials.

A lounge will be provided with refreshments, coffee, tea etc. at the competition venue for these VIP guests.

21.3. Opening Ceremony:

After the announcement of the opening ceremony and the cultural or sports' animation session, the delegations in sports wear, track suits, in suits or other appropriate attire, will parade preceded by a placard bearing the name of their country, in full or abbreviated, written in the language of the Organizing National Federation, or Olympic names, or abbreviations approved by the International Olympic Committee and their national flag (Flag and board bearers are from the Organizing National Federation). The sign holders leading the delegations shall stand still in vertical rows facing the designated Officials area.

The delegations' entry shall be in alphabetic order, accompanied by music. The organizing country shall enter last followed by referees and technical officials.

When all the delegations are present, the flags of the host country and of the IJF and of the IOC (for the IJF World Events as well as for the Olympic Qualification Events shall be raised; in no circumstances shall the IOC flag be displayed in such a manner that it could be included with any advertising materials in any photographic or video report).. Prior approval of the IOC must be given by the IOC. These flags shall remain raised for the all duration of the event.

During the playing of the host country's national anthem, all Officials shall raise until the last musical note of the national anthem is played.

The President of the host country National Federation shall give a speech, followed by that of the I.J.F. President who shall declare the opening of the event or delegate this honor to the highest authority present. High profile officials such as the IOC President, the President of the organizing country or Minister of Sports may also give official speeches.

The declaration of the opening of the event shall be done according to the formula "On behalf of ... I declare the opening of...Judo World Event ".

A presentation of the officials; officials of the IJF, other officials...will be done.

March out of the delegations.

The time allocated for this ceremony is 30 minutes including the cultural and sports' manifestations.

22. MEDALS, DIPLOMAS, AND AWARDS PRESENTATION CEREMONY

It shall take place after the conclusion of the last final of the day. Athletes dressed in their judogi shall be placed behind the podium according to the following order (2, 1, 3, 3). Each competitor having won a medal must be present at the ceremony and receive the medal personally, if possible. Any competitor who is absent from the awards ceremony without a good cause will forfeit his medal. It is strictly prohibited for athletes while on the

podium to have national flags or the like other than the ones fixed on their Judogi. Any demonstration with religious, political, personal or commercial connotation is prohibited as well as to bear a cap or any similar covers on the head. Officials who will present the medals shall be in a row facing their respective recipient. Officials chosen to give the award should be properly dressed.

The speaker of the ceremony must clearly announce the names, nationality and rank of the recipients as well as the capacity of the Officials presenting the medals. It is highly recommended that giant screens be used for the written announcement of medal recipients. At the announcement of the medal to be presented, the athlete should step up the podium, in the designated place. The Official shall advance at the same time as the hostess carrying the medals. The Official shall place the medal around the neck of the athlete. This shall be done for all the medal recipients (Gold 1st), (Silver 2nd), (Bronze 3rd, 2 third). All the awards shall be given after the gold medal is presented. Diplomas for the 5th and 7th placed competitors will be given to the respective chiefs of delegation and not to the athletes.

Flags shall be raised at the same time but with a slight difference of level between themselves (1st one on the top, 2nd one lower than the 1st one and the two 3rd ones lower than the others). When the national anthem (shortened version) of the winner's country is played, the Officials and athletes should turn toward the flags for salute.

Athletes' entry and leaving shall be accompanied by music. The awards must be presented in the following order:

Gold
Silver
Bronze (2)
Other Awards.

The honor of medal presentation belongs to the IJF President who can delegate this honor to high profile personalities.

In case a competition is taking place with the presence of a Government representative of the host country, an IOC representative, the IJF President and the President of the National Federation of the host country, the order of precedence will be determined in consultation with the IJF protocol officer.

Note: for the World championships by teams of nations: 4 trophies/cups will be put presented to the 4 teams on the podium and two additional medals will be presented to the team leaders of each team.

22.1. Closing Ceremony:

It shall take place after the presentation of the last medals of the last competition day with a parade of all participating delegations following the opening ceremony protocol. Before the announcement of the closure, the flags of the organizing country, of the IJF and of the IOC shall be lowered accompanied by music (not anthem). The President of National Federation hosting the event shall present the IJF flag to the IJF President who shall solemnly present it to the representative of the country, which will host the next IJF event.

22.2 Medals and Diplomas:

The Organizer should present each participant with a diploma certifying participation.

The Organizing National Federation must provide medals and diplomas for each weight category and the "open" category as follows:

1st place: one Gold medal and a diploma

2nd place: one Silver medal and a diploma

3rd places: two Bronze medals and diplomas. The winners of the repechage A and B are the Bronze medalists.

5th places: two diplomas. The finalists of the repechage A and B are the 5th placed.

7th places: two diplomas. The seventh are the losers of the final repechage fights.

Note: The diplomas of the 5th and 7th placed competitors are given to the team leader by the representative of the organizing committee.

22.3. Banquets:

During official dinners and banquets, the National Federation President of the organizing country shall be placed to the left of the IJF President. The IOC representative (or NOC) shall be seated to the right of the IJF President. Spouses shall occupy every other seat from these three personalities.

As much as possible, guests not in the official table shall be seated according to their status. Toasts and speeches shall be given at the moment of dessert.

The official dress code shall be observed during these ceremonies.

23. OTHER PROVISIONS

23.1 The sporting organization of the World Championships shall be under the control of the Sports Director and the Refereeing Director of the IJF according to the Statutes and by laws.

The organization of the Congress and the session of the Executive Committee shall be under the control of the General Secretary.

The organization of Symposia and Commission meetings shall be under the control of the Chairmen of these bodies.

23.2 The person nominated by the Executive Committee shall assume control of and responsibility for calling the competitors to the competition area, announcing the results of the matches and ensuring the correct order of the competition.

23.3 The first competitor called always wears a blue judogi and the second wears a white judogi.

23.4 Forfeit of match: a competitor who is not at his place after three calls at 1 minute intervals will forfeit the match. The athlete forfeiting a match may participate in the repechage provided the IJF jury found certain criteria are fulfilled.

23.5 When a competitor receives a direct "Hansoku Make" according to the Article N° 27 of the IJF Refereeing Rules he will be excluded from the competition.

23.6 In any case of misbehavior by a competitor, which merits disqualification, the Jury (the Executive Committee of the IJF) may exclude him from the rest of the championships (see also the applicable provisions of the article 23.8).

23.7 Code of dress for coach the coaches have to be dressed in their national tracksuit or wearing appropriate attire while coaching (to bear a cap or everything covers head, whatsoever it is, is forbidden). When the team leader will come to the control of nation to confirm the entries of their competitors the information related to the official judogi suppliers accepted, advertising will be recalled as well as the way on which the coaches have to be dressed.

The coaches have to place their personal effects under or behind the chair while they are coaching.

23.8 Unacceptable behavior:

Any official or member of a delegation, who disturbs or interrupts the orderly running of any and all activities relating to the IJF events and the action, may be declared "unacceptable" as an official by the Jury (the Executive Committee of the IJF). For all cases of behavior considered "unacceptable" during Events organized by the IJF or under the IJF auspices, a hearing will be conducted at the site ASAP during the event allowing the person, having undertaken behavior considered by IJF as unacceptable, to be heard by IJF Executive Committee or representatives of the IJF Executive Committee; he may be accompanied by a person of his choice, or be represented by another person.

The sanction can be for the event, several events:

- a ban of participation in one or several Judo events (championships, congress, seminar, etc.) in any capacity whatsoever.
- suspension from any competition for a period of 6 months to 4 years.
- a minimum fine of USD 1000.
- Thereafter his identity card may be withdrawn and he may be refused entry to any place under the IJF responsibility, in case of a tournament in any place except in the public galleries/seats.

The concerned Federation will be informed and additional consequences will possibly occur according to IJF Jury decision not only for the official but also for the Federation to which the official belongs.

In case of probation: procedure must be made immediately in case of probation violation and the sanction will start on the date the decision is made

Note: The order in which the different sanctions are enumerated is not of importance, since they are all available to the decision-making Jury. However, the sanction of suspension is the basic sanction and should, therefore, be first in any enumeration.

23.9 Competitors bowing procedure:

When making a standing bow before the start of contest (see Article 5 and 6 of the Refereeing Rules), the competitors must ensure that their judogi are properly adjusted (see Article 2 of the Refereeing Rules). The bow is then made simultaneously with the opponent by bending forward at the waist (30 degrees) and sliding the hands with the palms flat and thumbs forward down the outside of the trouser legs. Handshakes and other demonstrations should not take place on the mat.

Note: *For the complete bowing procedure (see Refereeing rules)*

23.10 Recommendation for various cases of Hansoku Make:

- a) In case of Hansoku Make resulting from “progressive” penalties, medals and places should be awarded,
- b) In case of direct Hansoku Make two possibilities arise:
 - if it is for “protection”, of the athlete (diving head first onto the mat...), medals and places should be awarded
 - if it is for acts against Judo spirit, the IJF Jury will make decision
- c) In case of simultaneous Hansoku Make resulting from successive penalties (after the third Shido), the Golden Score will be applied (situation similar to simultaneous Ippon/Victory).
- d) In case of simultaneous direct Hansoku Make, repechages will be organized among the competitors defeated by the “disqualified ones” whenever it will be possible.

23.11 Situation not covered by the rules:

When any situation arise which is not covered by these rules, it shall be dealt with, and a decision made by the IJF Sports Commission or/and the IJF EC.

The code is to be utilized and adhered to in the following:

- a) Summer Olympic Games where applicable, and World Championships.**
- b) All other events conduct or controlled by the IJF, including the IJF events.**
- c) Games of the Unions.**
- d) Continental championships/tournaments.**
- e) Events listed on the calendar of the IJF.**
- f) Regional championships/tournaments.**
- g) Events conducted by a national Federation in which a competitor obtains for his National Olympic Committee the right to select a competitor to participate in a summer Olympic Games.**

24. CHECK-LIST

24.1 Application for holding of World Championships:

The written application, to be sent to the General Secretariat of the IJF must contain the following:

- a) name of event
- b) men/women
- c) age group
- d) weight categories
- e) place and date of the holding of the World Championships
- f) assurances of:
 - 1) observance of Statutes, Finance rules, SOR and Refereeing Rules of the IJF
 - 2) unimpeded entry into the country and participation in the World Championships for the IJF member countries/federations
 - 3) Consent of the Continental Union to the holding of the World Championships
 - 4) information about the competition site, accommodation and facilities
 - 5) information about financial guarantees for the World Championships

24.2 Overall Program for the Organization and Holding of World Championships:

The Organizing Member Federation (OMF) shall work out an overall program for the organization and holding of World Championships.

This program must be submitted to the Organization Commission of the IJF within three months after having accepted the organization of the World Championships.

Contents of the overall program:

- a) Overall timetable including all the necessary activities
- b) Overall financial plan
- c) Overall organization plan

24.3 Overall timetable:

- a) Date and place of the first joint meeting of IJF Organization Commission and OMF.
- b) Date of circulation of the first general information to the National Judo Federations by the OMF.
- c) Date of circulation of the invitations of the World Championships by the General Secretary of the IJF
- d) Date of control of all facilities needed for the holding of the World Championships by the IJF.
- e) Date of deadline for original entries (numbers).
- f) Date of nomination of the officials, Jury members and referees by the IJF.
- g) Date of sending out invitations to the officials, Jury members and referees by the OMF.
- h) Date of the dispatch of the flight tickets to those persons paid by the OMF.
- I) Date of deadline for final entries (names).
- j) Date and place of the opening of the Information and Reception Office.
- k) Date of arrival of Executive Committee members, officials, Jury members, referees and participants
- l) Timetable for training hours for participating countries/federations.
- m) Timetable for local transport.
- n) Date of control and approval of all facilities by the IJF Executive Committee and the OMF.
- o) Date and place of the control of the entries of the participating countries.
- p) Date and place of control of flags and anthems.
- q) Date of dress rehearsal (opening ceremony, closing ceremony, work of the staff at the tables).
- r) Date and place of draw.
- s) Date and place of weigh-in.
- t) Competition timetable.
- u) Timetable of opening and closing ceremonies.
- v) Timetable of prize giving ceremony.
- w) Times of doping control and gender control (where applicable).
- x) Times of press conferences and interviews with the winners.
- y) Timetable of sessions and conferences.

24.4 Overall Financial Plan:

- a) Deposit of guarantee sum to IJF.
- b) Result of contract for TV rights obtained by the IJF together with the OMF.
- c) Fixing of costs for:
 - 1) IJF representatives to be borne by the OMF (costs of travel and stay including one day before and one day after the activities and two days before for the Sports Director and Refereeing Director).
 - 2) the Sports Commission
 - 3) the Refereeing Commission
 - 4) the Education Commission (for the Senior World Championships)
 - 5) the Referees
 - 6) the IJF Medical Commissioner
 - 7) the IJF Media Commissioner
 - 8) the IJF Technology Specialist
 - 9) doping control, gender control, including laboratory tests

24.5 Overall Organization Plan:

- a) **Official invitation:**
 - 1) Invitation letter
 - 2) Program
 - 3) General information concerning organization

- 4) World Championships regulations
- 5) Original entries/number (two copies) Entry copies : one for the General Secretary
- 6) Final entries/names (two copies) : one for the Organizing Committee, one for the IJF GS.

b) Control of Participants:

- 1) name
- 2) citizenship
- 3) age
- 4) weight
- 5) gender
- 6) IJF unique identification number (ORIS)
- 7) distribution of identity cards

c) Control of the National Anthems and Flags by the Chiefs of Delegations of the Participating National Federations.

d) Draw:

- 1) a computer
- 2) IJF software, or an IJF approved software.
- 3) printer
- 4) video projector
- 5) screen
- 6) room with a capacity of 300 individuals
- 7) central table for 12 individuals
- 8) an official table for the IJF EC Members attending the draw
- 9) equipment for a manual draw (in case of necessity), lots, ballots, cups...
- 10) contest system lists
- 11) 2-4 large blackboards
- 12) contest drawing lists per weight category corresponding to the number of competitors
- 13) nameplates (for the manual draw)
- 14) microphone on the central table
- 15) copy machines with sorter (high capacity minimum two)

e) Weigh-in (separate rooms for men and women) :

- 1) facilities for unofficial weigh-in, facilities shall be opened from the arrival of the first delegation
- 2) official weigh-in (separate rooms of ca. 100 m²)
- 3) 6 weighing scales (not of the spring type) of guaranteed accuracy, 2 per room and 1 scale in reserve for each room
- 4) two (2) tables, eight (8) chairs (by room)
- 5) cloakroom where competitors can leave their clothing
- 6) eight (8) assistants, two (2) per weighing machine and a technician able to calibrate the machine (four (4) female assistants, among the eight assistants, for the female weigh-in)
- 7) two (2) weigh-in lists per weight category
- 8) writing materials

f) Judogi Control:

- 1) measures devices
- 2) two lists per weight category
- 3) writing materials
- 4) adhesive tape to cover if necessary not acceptable markings

g) Printed materials:

- 1) invitations
- 2) entry forms
- 3) registration forms for accommodation, arrival, departure, training hours, food, tickets
- 4) posters
- 5) program
- 6) diplomas for all participants and per weight category 1 x 1st place, 1 x 2nd place, 2 x 3rd places, 2 x 5th places, 2 x 7th places
- 7) contest system lists
- 8) contest record

- 9) weigh-in lists
- 10) contests' order
- 11) lists for the order of the referees officiating
- 12) summons for participation in doping control and in gender control (where applicable)
- 13) record of urine test and record for gender control (where applicable)
- 14) result sheets
- 15) identity cards
- 16) forms for the draw
- 17) Back Identification (for the fighters) generally black on white either 30 cm x 30 cm or 30 cm x 40 cm

h) Medals:

- 1) medals per weight category: 1 Gold, 1 Silver and 2 Bronze
- 2) medals for the World Championships by Team of Nations: 16 (14 + 2) Gold, 16 (14 + 2) Silver and 32 (2 x 14 + 2 x 2) Bronzes

i) Rooms:

- 1) competition venue with detached interior, large enough for 4 competition areas for the Senior WC, 3 for the Junior WC and 3 (minimum) for the World Championships by Team of Nations, 2 for the Olympic Games and the necessary installation
- 2) warming-up room with ca. 400/600 m² tatami surface
- 3) training opportunities for all competitors
- 4) recreation room for Executive Committee
- 5) recreation room for Referees
- 6) recreation room for Refereeing Commission
- 7) recreation room for Sports Commission
- 8) recreation room for the Education Commission (where applicable)
- 9) dressing rooms capable of being locked for the competitors complete with massage facilities, toilets and showers
- 10) rooms for anti-doping control and gender control (two separate rooms, one for men, and one for women)
- 11) room for medical treatment
- 12) installation of a Press center with the necessary facilities (telex, telephone, typewriters, fax)
- 13) room for press conferences
- 14) separate lunch-rooms for Executive Committee, the Officials, the IJF Guests, referees, participants and spectators
- 15) conference room for about 50 persons
- 16) rooms for the Organizing Committee
- 17) Office for the President of the IJF
- 18) Office for the General Secretary and the General Treasurer of the IJF, with a room for the IJF Administrative Secretariat equipped with computers, printers, copy machines with sorter, telephone, fax and internet connection
- 19) Office for the IJF Vice Presidents
- 20) A secretariat (equipped with computers, printers, copy machines with sorters, telephone, fax, high speed internet access)
- 21) rooms for non official weigh-in at the competition site
- 22) rooms for the Organizing Committee at the hotel
- 23) rooms for the official weigh-in at the hotel ; in the village for the Olympic Games (two separate rooms for men and women)
- 24) room for draw with a capacity of minimum 300 individuals
- 25) room for the "control of the entries"
- 26) room for the IJF Congress, ca. 350 individuals, complete with simultaneous translation facilities
- 27) 5 rooms for the Unions' Congresses
- 28) room for the Medical Symposium (if decided by the IJF EC)
- 29) room for Executive Committee sessions
- 30) room for Sports Commission meetings
- 31) room for Refereeing Commission meetings
- 32) room for the Education Commission meetings (for Senior World Championships)

j) Personnel requirements and IJF officials

- 1 President
- 5 Vice-Presidents
- 1 General Secretary

- 1 General Treasurer
- 1 Sports Director
- 1 Refereeing Director
- 1 Education and Coaching Director
- 5 Sports Commission members (+ 1 assistant)
- 5 Refereeing Commission members (+ 1 assistant)
- 5 Education Commission members (for Senior Men/Women World Championships). (+ 1 assistant)
- 2 to 4 Administrative Secretaries
- 1 IJF Technology Expert
- 1 IJF Medical Commissioner
- 1 IJF Media Commissioner
- 40 IJF Referees for Senior Men/Women World Championships
- 25 to 26 IJF Referees for the Olympic Games
- 24 IJF Referees for World Championships for Men and Women under 20

k) Medical Personnel

- 1) one doctor per mat
- 2) two medical assistants
- 3) two doctors for anti-doping control and gender control (where applicable)
- 4) sufficient medical personnel to attend to the official participants at the competition venue and at the hotel

l) Table Staff for each competition area

- 1 speaker (official languages English French and Spanish)
- 1 list writer
- 1 administrator
- 2 recorders
- 1 timekeeper for contest time
- 1 timekeeper for osae-komi time
- 1 assistant for the Refereeing Commission
- 1 messenger
- 1 staff member who is responsible for ensuring the functioning of the proper sport-technical equipment
- 2 staff members responsible for controlling the competitors before a contest
- 2 attendants for the contestants
- Security staff as required

m) 1 Central Speaker

n) Ceremonies

- 1 person responsible for ceremonies and protocol questions
- 5 assistants for the awards ceremony
- 5 assistants for the opening and closing ceremonies

o) Internal Organization

- 1 Head of the Organizing Office
- 1 Head of the Information and Reception Office
- 1 person responsible for accommodation and food
- 1 person responsible for training
- 1 person responsible for transport
- 1 person responsible for supplies
- 1 person responsible for Public Relations
- 1 person responsible for materials and equipment
- 1 person responsible for the secretariat
- 1 person responsible for the weigh-in
- 1 person responsible for the draw
- 1 person responsible for the control of the competitors
- 10 assistants for control of citizenship, entries, distribution of identity cards, control of flags and anthems.

p) Equipment Requirements

- 1) 4 competition areas for the Senior WC, 3 for the Junior WC and 2 for the Olympics (quality of the tatamis must be approved by the IJF).
- 2) 400/600 m² warming-up room

- 3) 1 "stand by" area of 20 to 40 m2 allowing the 'checked' competitors to wait before their contest and to see the competitions
- 4) 1 platform for the competition areas (if requested by the IJF EC and quality must be approved by the IJF)
- 5) 2 chairs with cases for referee's flags for the judges per competition areas
- 6) 3 blue referee's flags per competition area
- 7) 3 white referee's flags per competition area
- 8) 1 complete equipment with two electronic scoreboards per competition area
- 9) 1 central table with 20 chairs for the Executive Committee (Jury) of the IJF
- 10) 1 table for the direction of the Event with 6 chairs (IJF Sports Director and IJF Refereeing Director, local Competition Manager, IJF statistician, assistant)
- 11) 1 table per competition area with 16 chairs for the table staff
- 12) 1 microphone per table
- 13) 1 audible device for manual operation per competition area
- 14) 1 gong per competition area with different sounds
- 15) 4 stopwatches per competition area
- 16) 1 yellow flag by competition area
- 17) 1 green flag by competition area
- 18) 1 information board per competition area for calling competitors and referees
- 19) 1 table for pre-contest control (per competition area)
- 20) 1 table and 2 chairs for the competition area doctor (per competition area)
- 21) 2 chairs for the competitors' doctors (per competition area near the medical table)
- 22) 2 chairs for the competitors' coaches (per competition area)
- 23) chairs per competition area for the referees (according the number but minimum 12 chairs by competition area)
- 24) 1 central microphone
- 25) 1 radio microphone per competition area for the referee
- 26) sufficient cloakrooms must be available in the weigh-in rooms, the warming-up room and the training rooms
- 27) portable boards bearing the names of the participating countries
- 28) national or delegation flags of the participating countries with flag-staffs
- 29) national or delegation anthems (shortened version) of the participating countries
- 30) flags of participating countries for the awards ceremony
- 31) site for the awards ceremony
- 32) platform for the awards ceremony
- 33) 3 IJF flags
- 34) IOC flag
- 35) national flag of the host country
- 36) sewing machines for sewing on back identification
- 37) 20 to 40 judogis 10 per competition area (as reserve, blue and white)
- 38) "measuring devices" for the judogis control

q) Information Concerning Conditions and Quality of Equipment

- 1) Any equipment needed for the holding of the competitions must be controlled and approved by authorized members of the Executive Committee of the IJF
- 2) The competition venue shall be equipped in such a way that there are optimum conditions for the competitors, referees, table staff, officials and spectators.
- 3) Press, TV and photo-reporters must not impede the competitions.
- 4) The competition venue for the Senior World Championships should have a seating capacity for at least 8.000 to 10.000 spectators. A temperature of 18 degrees centigrade shall be ensured.
- 5) Provision shall be made for even lighting of the competition area. Lighting must be directed on the area from the top above. The lowest permissible lighting level is 1.500 lux (1800 lux is the best level).
- 6) The seats for the officials shall be marked with their names. Special seats shall be available for guests of honor, accredited journalists and competitors
- 7) All rooms for officials, referees and competitors shall be equipped with loudspeakers. In the competition hall all information shall appear on a large electronic scoreboard.

r) Training rooms

- 1) The number of training rooms shall correspond to the number of competitors. The training rooms and training hours shall be assigned to the participating National Federations in a way that equal treatment is given.
- 2) The training rooms shall be equipped corresponding to the required standard. Individual training for

all participating national federations must be guaranteed. A training surface of 60 m² will be accepted as a minimum.

3) Dressing rooms, showers and weighing machines shall be available at the training site.

s) Information and Reception Office

An Information and Reception Office shall be set up at the central hotel and an information office, at the competition venue. From there all information will be forwarded to the participating national federations.

The office is responsible for:

- 1) receiving all participants on arrival and for their departure
- 2) allocation of hotel rooms,
- 3) assistance in ordering meals,
- 4) assistance in transport (local and flight reservations),
- 5) supplying of information of all kind,
- 6) reservation of training hours,
- 7) assistance in cultural and tourist matters.

t) Entry and Citizenship Control, Distribution of Identity Cards

These controls should not take more than two hours. Rooms and working conditions must correspond to the number of entries and should include as a minimum.

- 1) large table for administrative work
- 2) 5 separate tables for the Unions
- 3) 1 table for the General Secretary and the General Treasurer
- 4) 1 table for the preparation of the draw
- 5) 30 chairs

u) Press center

Size and equipment of the Press center shall correspond to the number of accreditations. Working conditions must be in line with the AIPS standard, see 19.

- 1) Telephones lines allowing Internet access as well as high speed Internet connections
- 2) Telex
- 3) fax
- 4) telephones
- 5) typewriters
- 6) interview facilities
- 7) specially equipped spectator seats for journalists
- 8) Copy machines

v) Congress

The Congress hall shall be of representative character and equipped with simultaneous translation facilities and contain at a minimum

- 1) 1 table for the Executive Committee of the IJF, 15 chairs for the Executive Committee table
- 2) 1 table and chairs for the IJF Honorary Members and the IJF Guests
- 3) 1 central microphone for the President of the IJF
- 4) 3 to 5 microphones for the Executive Committee table
- 5) 2 microphones for the delegates of the Congress
- 6) 350 seats and corresponding working conditions for the participants in the Congress
- 7) Simultaneous translation in the official languages of the IJF and, if possible, in the auxiliary languages of the IJF
- 8) Nameplates for the Executive Committee members and IJF Honorary Members and the IJF Guests
- 9) Nameplates for the participating countries
- 10) IJF flags and IOC flag
- 11) soft drinks, snacks
- 12) technical facilities necessary to record the proceedings of the Congress
- 13) typing pool
- 14) copy machines
- 15) 2 voting booths
- 16) 1 voting box
- 17) ballots.

25. STANDARD FORMS FOR WORLD CHAMPIONSHIPS AND INTERNATIONAL EVENTS

- Contest list for up to 32 participants.
- Contest list for up to 64 participants.
- Contest Sheet.
- Example of repechage and classification
- Winner's List.
- Weigh-in List.
- List of Official for Weigh-in and Control
- Judogi Control List (advertising).
- Control Card and sample.
- Contest Order.
- Referees' list

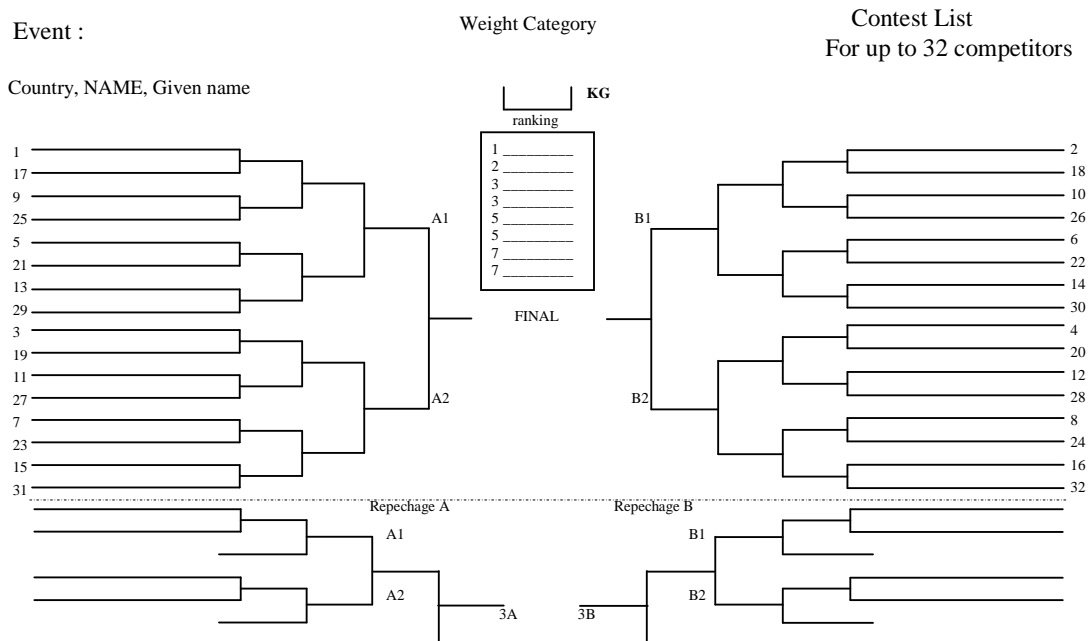

Event :

Weight Category

Contest list

Country, NAME, Given name

Ranking

From up to 64 competitors

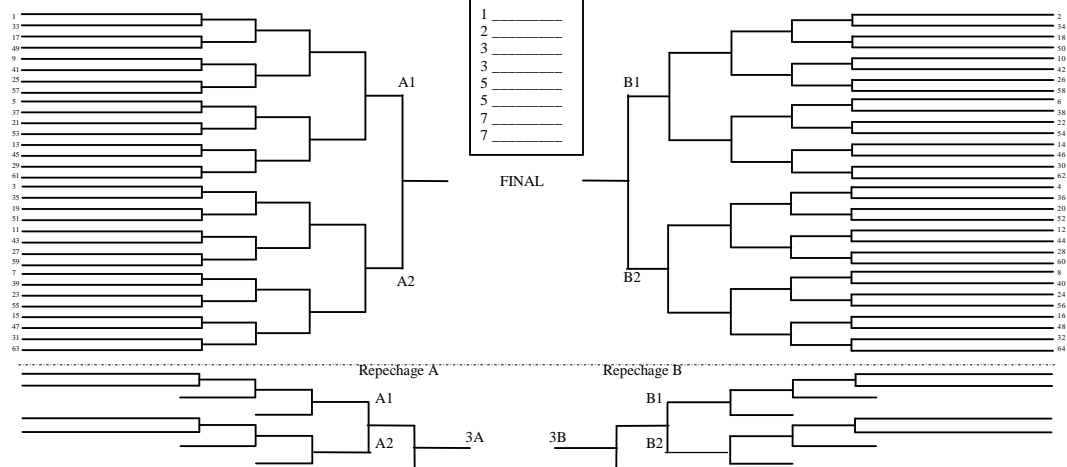

Event:

Weight Category

Exemple of repechage and ranking

Country, NAME, Given name

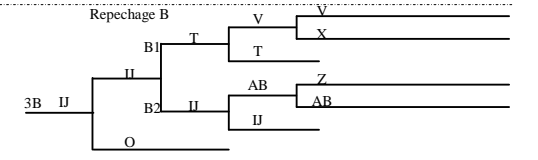
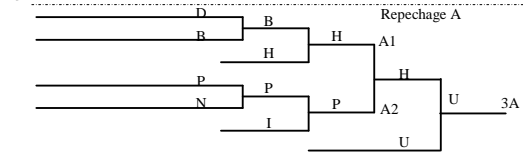
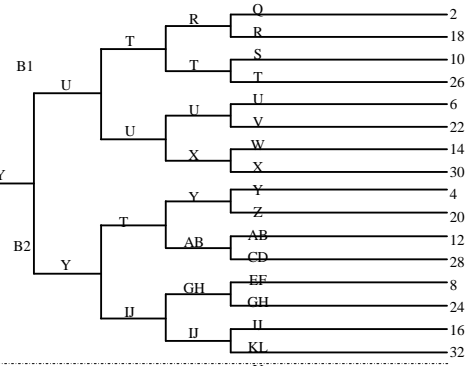
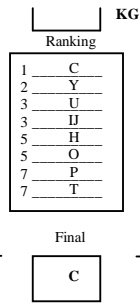
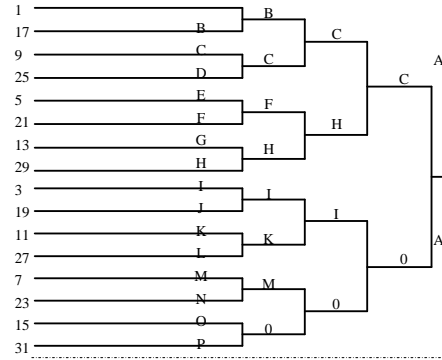

Feuille des médaillés
Winner's list

Categorie de poids Weight category	kg		date	N°
---------------------------------------	----	--	------	----

Place	Nom Surname	Pays Country	Medaille Medals
1			Or Gold
2			Argent Silver
3			Bronze
3			Bronze
5			
5			
7			
7			

LIST OF OFFICIALS FOR WEIGH-IN
LISTE DES OFFICIELS DELEGUES A LA PESEE

Médaille
Medals

	N°
--	----

Jour/Day	Nom/Surname
----------	-------------

Jour/Day	Nom/Surname
----------	-------------

Jour/Day	Nom/Surname
----------	-------------

Information

Signature



CONTROL CARD CARTE DE CONTROLE

Code Athlete	J U	IJF visa FIJ
Country Pays		
Fam. - Name Nom de Fam.		
First Name Prénom		
Date of Birth Date de naissance	Day/Jour Month/Mois 19	Draw Nr. No. tirage au sort
Weight category / Catégorie de poids		
Signature of the Federation Signature de la Fédération		



PASS LAISSEZ-PASSER

Photo	Code Athlete J U
	Name _____ Country/Pays _____ Nom _____ First Name _____ Prénom _____
	Date of Birth _____ Weight category _____ Date de naissance _____ Catégorie de poids _____
	Event/Manifestation _____ Year/Année 20 _____
Stamp of the Organizer Cachet de l'Organisateur	IJF Control FIJ Controle



CONTROL CARD CARTE DE CONTROLE

Code Athlete	J U B E L 2 1 2 0 1 1 9 6 2 0 1				IJF visa FIJ
Country Pays	BELGIQUE				
Fam. - Name Nom de Fam.	WAN DER BROOKE				
First Name Prénom	Gaelle				
Date of Birth Date de naissance	Day/Jour 12	Month/Mois 01		19 62	Draw Nr. No. tirage au sort
Weight category / Catégorie de poids	- 78				
Signature of the Federation Signature de la Fédération					



PASS LAISSEZ-PASSER

Photo	Code Athlete	J U B E L 2 1 2 0 1 1 9 6 2 0 1				
	Name Nom	WAN DER BROOKE			Country/Pays	
	First Name Prénom	Gaelle			B E L	
	Date of Birth Date de naissance	1 2 0 1 1 9 6 2			Weight category Catégorie de poids	- 78
	Event/Manifestation	World Championships			Year/Année	20-11
	Stamp of the Organizer Cachet de l'organisateur	IJF	Control Controle			FIJ

26 Annexes

- Annex 1 : Regulations for Competitions by Team.
- Annex 2 : Regulation related to specific competitions
- Annex 3 : Recommendations Related to Weight Categories and Age for Youth.
- Annex 4 : Advertising.
- Annex 5 : Marking Allowed on Judogis.
- Annex 6: Technical Delegate Nomination Procedure

ANNEX 1 REGULATIONS FOR TEAM EVENT (Men and Women)

1) TEAMS

Each team will consist of 7 (seven) competitors (for Men as well as for Women)

Note: the masculine gender used in relation to any physical person shall, unless there is a specific provision to the contrary, be understood as including the feminine gender.

Weight Categories:

1.2) Women

Extra Light weight	- up to and including 48 Kg
Half Light weight	- over 48 Kg up to and including 52 Kg
Light weight	- over 52 Kg up to and including 57 Kg
Half Middle weight	- over 57 Kg up to and including 63 Kg
Middle weight	- over 63 Kg up to and including 70 Kg
Half Heavy weight	- over 70 Kg up to and including 78 Kg
Heavy weight	- over 78 Kg

1.3) Men

Extra Light weight	- up to and including 60 Kg
Half Light weight	- over 60 Kg up to and including 66Kg
Light weight	- over 66 Kg up to and including 73 Kg
Half Middle weight	- over 73 Kg up to and including 81 Kg
Middle weight	- over 81 Kg up to and including 90 Kg
Half Heavy weight	- over 90 Kg up to and including 100 Kg
Heavy weight	- over 100 Kg

The team contests will be fought in the above order. Each competitor is entitled to fight in his own weight category or in the next higher category. A reserve is allowed for each weight category. A team consists of 7 (seven) competitors and has the possibility to have up to 7 (seven) reserves. A team has to consist of minimum 5 (five) competitors.

2) CONTROL OF THE RIGHT TO COMPETE

During the control (based on the Sport and Organization Rules of the IJF), identity, gender and weight category in which the competitors have been entered will be checked:

2.1) Check of the nationality of the competitors:

Competitors must be of the same nationality as the country enters them.

Proof of identity will be established by production of a passport or an official document or its copy from the country for which the competitor has been entered and then the control card will be issued for the competitor. If a competitor has more than one nationality, such competitor can only represent one country and thereafter may not represent any other country, until after a period of three (3) years has elapsed. If the two federations concerned wish so, they can ask the IJF to reduce or even to suppress this delay in conformity with the Sport and Organization Rules of the IJF and the Olympic Chart, point 46. Only one person of a National Federation shall be permitted to attend the control and shall produce the competitors' documents.

2.2) Age:

No limits

2.3) Insurance:

Each National Federation is responsible for its competitors (the control of non pregnancy is placed under the responsibility of the National Federations as well the gender control) and must assume all responsibility for accident and health insurance as well as the civil liabilities for their competitors and officials, including the nominated referees, during the event.

3) REFEREEING

Each team has to bring an IJF International Referee. IJF International Referees in accordance with the Refereeing Rules of the IJF will referee the contests.

For each contest three referees will be appointed who will not be of the same nationality than the competitors. In no circumstances the competitors or their representatives can consult the Refereeing Committee. The Committee is not an appeal's jury.

No appeal/protest against the referees' decisions will be accepted.

4) SYSTEM OF COMPETITION

The method of competition will be the elimination system with double repechage, i.e. the teams will be divided into two tables (four groups) by means of a draw and an elimination system will be used to produce two finalists. All teams defeated by the group winners A1, A2, B1, and B2 will take part in the repechage of their respective pools according to the elimination system; The final contests of repechages will be against the losers of the final of each respective other table.

The teams winners (2) of those contests are placed "third", the teams losers (2) of those contests are placed "fifth".

There must be a minimum of three teams in order for a title to be awarded.

5) COMPOSITION OF THE TEAMS

Before each round the team leader must present to the Organizing Committee the composition of his team.

At each round he has the right to replace one or several fighters by other(s) fighters of the corresponding weight category or of the next lower category (see point 1)

6) SEEDING FOR THE WORLD CHAMPIONSHIPS BY TEAM OF NATIONS

6.1 The seeding will take into consideration the results of the team individual members present based on the previous world championships.

6.2 Teams of the same Union must be separated to a maximum when possible taking into consideration the ranking in the Union.

7) DURATION OF CONTESTS (real contest time):

Each contest will be of **five (5)** minutes for **the Men and Women Events.**

8) DECISION

For each contest the following scoring system will be applied:

Ippon Gachi	10 points
Sogo Gachi	10 points
Fusen Gachi	10 points
Kiken Gachi	10 points
Hansoku-make	10 points
Waza-ari	7 points
3 Shidos	7 points
Yuko	5 points
2 Shidos	5 points
Koka	3 points
1 Shido	3 points
Yusei-Gachi	1 points

If at the end of the contest there is not at least a difference of a Koka between the two competitors, the referee will declare a draw (Hiki-wake).

The number of contests won will decide the winning team. If the number of contests won is the same, the result will be decided on the number of points scored.

In the case that the number of victories and points score is equal, the contest(s) with a draw result will be repeated under the Golden Score system. In this case one (1) point only will be awarded for a victory obtained by the application of the Golden Score.

If for any reason it is impossible to designate the winner team according to the above, the Sports Direction of the concerned Organizing Committee will proceed to a draw which will oppose in three weight categories the competitors having previously participated in the former contest. In these cases the referees must take an obligatory decision.

9) ANTI-DOPING CONTROL

The Anti-Doping Control will take place after the award ceremony. From each medal winner team two (2) competitors, having participated in the last fight, determined by draw, will be submitted to the control.

10) GENDER CONTROL

A Gender Control will be organized. The female competitors nominated for the anti-doping control will have also to undergo the Gender Control. The competitor able to produce a gender certificate issued by an official institution or an authorized person will be exempted (I.J.F. recognizes certificates issued by the IOC, the Unions).

ANNEX 2: REGULATIONS RELATED TO SPECIFIC COMPETITIONS

(with a 'low' number of competitors)

Small number of participants:

When there is less than 6 competitors (5, 4, 3), it is recommended to offer to the participants the choice to compete two (2) times minimum.

1) In case of 5 competitors:

a) 2 competitors on one side of the table, simple fight for the access to the final, the three others on the other side of the table fight with the round robin system in order to classify them.

b) The defeated competitor of the single fight has to fight with the second one coming from the round robin elimination for the bronze medal (one).

c) The winner of the single fight meets the winner coming from the round robin system for gold and silver.

2) In case of 4 competitors:

two single contests then one (1) contest between the two defeated ones for the bronze medal (one) and one (1) contest between the winners for gold and silver.

3) In case of 3 competitors:

only a round robin system produces the gold and silver and no 3rd place except if he has won one fight.

ANNEX 3: Regulations related to weight categories, age & contest time duration (Senior & Juniors) and recommendations for Youths

Senior Men, Men -20 and Youths					
SENIORS	-20 YEARS	15/16 YEARS	13/14 YEARS	11/12 YEARS	9/10 YEARS
5 minutes	4 minutes	3 minutes	3 minutes	2 minutes	No competition
				- 24 kg	
				- 27 kg	
				- 30 kg	
			- 34 kg	- 34 kg	
			- 38 kg	- 38 kg	
			- 42 kg	- 42 kg	
			- 46 kg	- 46 kg	
		- 50 kg	- 50 kg	- 50 kg	
		- 55 kg	- 55 kg		
- 60 kg	- 60 kg	- 60 kg	- 60 kg		
- 66 kg	- 66 kg	- 66 kg	- 66 kg		
- 73 kg	- 73 kg	- 73 kg			
- 81 kg	- 81 kg	- 81 kg			
- 90 kg	- 90 kg	- 90 kg			
-100 kg	-100 kg	+ 90 kg			
+ 100 kg	+ 100 kg				

Senior Women, Women -20 and Youths					
SENIORS	-20 YEARS	15/16 YEARS	13/14 YEARS	11/12 YEARS	9/10 YEARS
5 minutes	4 minutes	3 minutes	3 minutes	2 minutes	No competition
				- 22 kg	
				- 25 kg	
				- 28 kg	
			- 32 kg	- 32 kg	
			- 36 kg	- 36 kg	
			- 40 kg	- 40 kg	
			- 44 kg	- 44 kg	
- 48 kg	- 48 kg	- 48 kg	- 48 kg	- 48 kg	
- 52 kg	- 52 kg	- 52 kg	- 52 kg		
- 57 kg	- 57 kg	- 57 kg	- 57 kg		
- 63 kg	- 63 kg	- 63 kg	- 63 kg		
- 70 kg	- 70 kg	- 70 kg			
- 78 kg	- 78 kg	+ 70 kg			
+ 78 KG	+ 78 kg				

ANNEX 4: ADVERTISING

The competitors and their judogi shall be checked and found to be in accordance with the Refereeing Rules of the IJF and SOR requirements, (Article 3 - Judo uniform and Article 4 - Hygiene), prior to each contest.

Note: the blue color standards must be between the pantone numbers n° 18-4051 and n° 18-4039 on the pantone scale of TP or n° 285 or n° 286 on the pantone scale for print.

Each National Federation must ensure that the advertising appearing on the Judogis of its competitors are abiding by the IJF Rules, as indicated below. All Judogi not abiding by the rules will be rejected.

Are allowed:

- on each shoulder either the same advertising or the national colors (25 cm x 5 cm)
- on each sleeve in contact with the stripes of 25 cm x 5 cm one area of 10 cm x 10 cm (different advertising accepted).

IJF Official suppliers are authorized to place IJF Logo of "IJF Official Supplier" above their trade mark logo.

For the Olympic Games all advertising is prohibited, except the trade mark logo of 20 cm² (see annex n° 5)

1er possibilité / 1st possibility

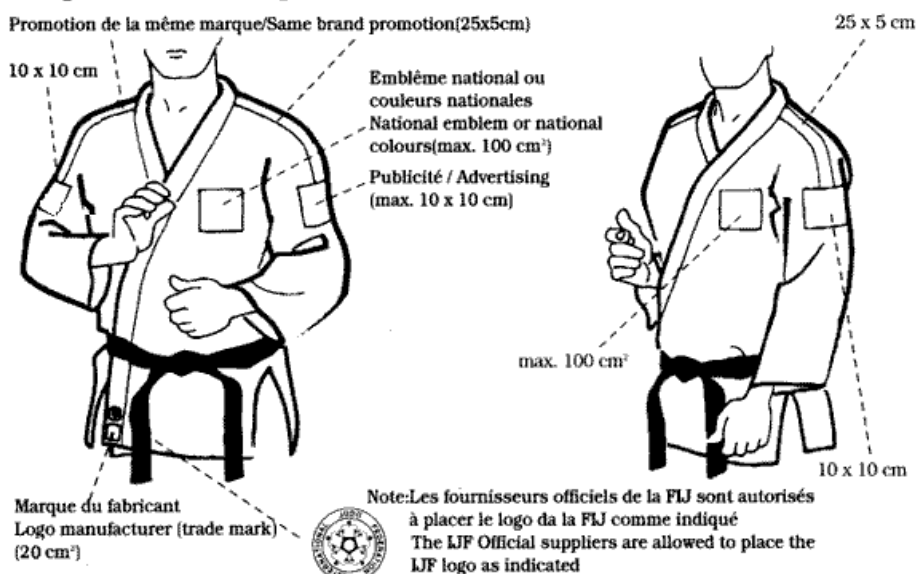

2e possibilité / 2nd possibility

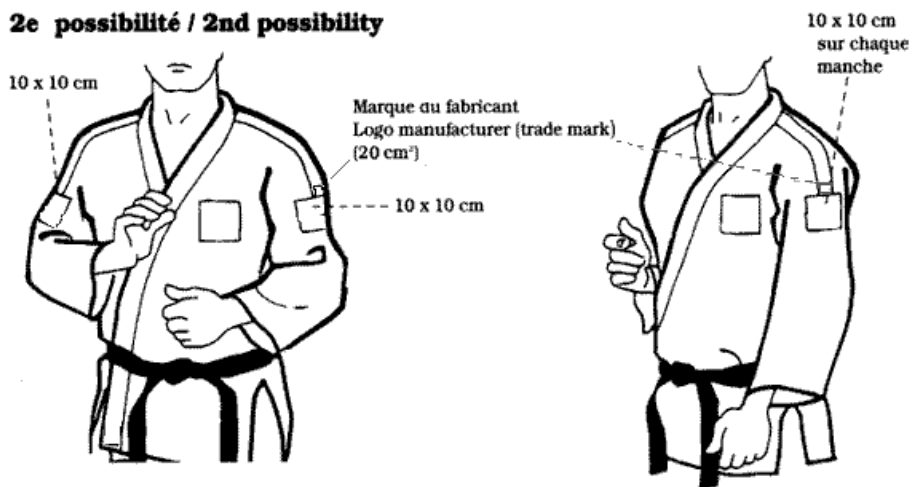

Il est admis de placer le logo du fournisseur sur une des manches mais à l'intérieur de l'aire 25 x 5 cm au lieu du bas sur le devant de la veste.

It is admitted to place the logo manufacturer on one of the sleeves but inside the 25 x 5 cm area instead of at the bottom front of the jacket.

ANNEX 5: MARKING ALLOWED ON JUDOGIS

- a) National Olympic Abbreviation (see 14.2)
- b) National emblem (on left breast of jacket), maximum size 100 cm².
- c) One manufacturer's trademark (on bottom, left side of the jacket), maximum size 20 cm².
- d) One manufacturer's trademark (on bottom, in front of the left leg of the trouser), maximum size 20 cm².
- e) One manufacturer's trademark at one end of the belt, maximum size 20 cm².
- f) Indication of the placing (1st, 2nd, 3rd) at the Olympic Games or World Championships, in an area of 6 cm x 10 cm on bottom, front of the left side of the jacket or by the use of different colors on the Bibs.
- g) Name of the competitor can be placed (printed, embroidered in the back of the jacket) but in no case placed in a position to prevent an opponent from grasping the back of the jacket. The size of the letters is maximum 7cm high; length of the name is 30 cm maximum (a maximum of 12 letters or less is recommended). This rectangular area of 7 x 30 cm must be located at 3 cm under the collar of the jacket, the back identification must be fixed at 4 cm under this area (see annex n° 5).

Note: for the Summer Olympic Games as well as IJF Events the manufacturers trade mark allowed are 20 cm² from Athens 2004 Olympic Games.

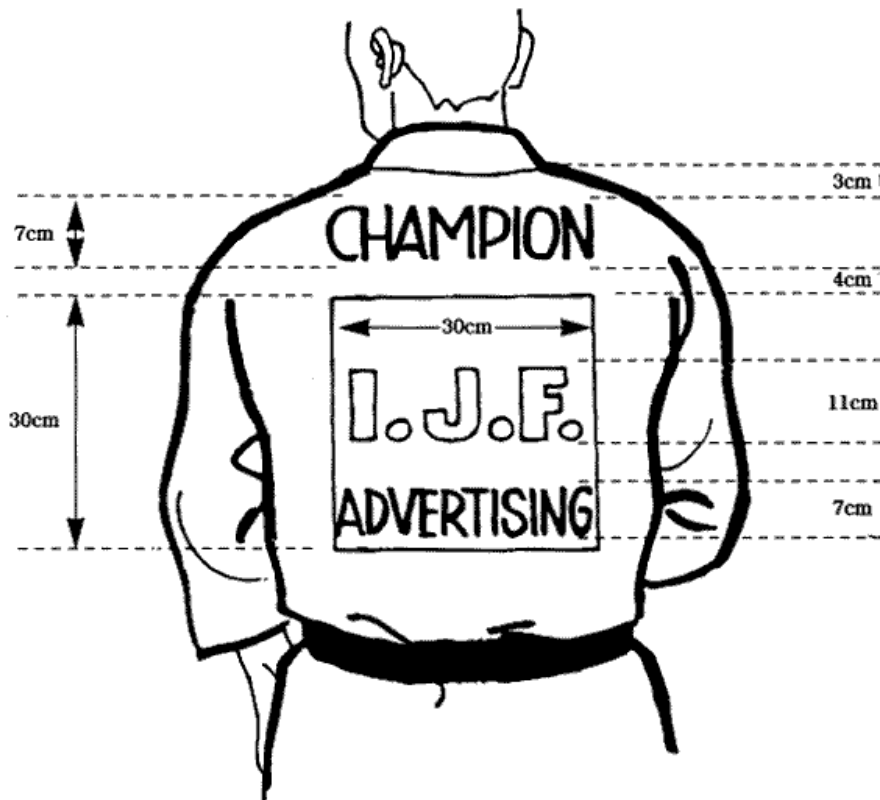

ANNEX 6: TECHNICAL DELEGATE NOMINATION PROCEDURE

1. In all IJF Events, the Sports Director and the Referee Director are the Technical Delegates in their respective fields as defined by the IJF Statutes.
2. In a Continental Union or National Federation Event, the corresponding Continental Union or National Federation "may" request to the IJF for the nomination of a Technical Delegate.
3. In a Multi-Continental Union event, the organizers must request to the IJF for the nomination of a Technical Delegate.
4. If a Continental Union or National Federation Event is considered as an Olympic Qualification tournament, the organizer "must" request for the nomination of a Technical Delegate to the IJF Sports Director:
 - the IJF Sports Director will submit a nomination of one Technical Delegate to the IJF Executive Committee and if the IJF EC approves, this one will officiate as such TD for the related Event.
 - the same procedure will be used for Refereeing, the IJF Referee Director will submit a nomination of one Technical Delegate to the IJF Executive Committee and if the IJF EC approves, this one will officiate as such TD for the related Event.

27. COPYRIGHT

Sports and of Organization Rules of the IJF

1. Any Federation Member can use and reproduce Sports and of Organization Rules of the IJF, etc. for the own necessities to insure its distribution under reserves that it is not for commercial purposes.
2. Any Federation Member of the IJF or every person wishing to print all or any of this Sports and Organization Rules of the IJF in commercial purposes has to make the demand of it with the IJF which will fix the amount of rights to pay.
3. Any Federation Member can make a translation of these official texts (published in English, French, and Spanish) in its own language but in that case has to indicate mention «unofficial translation ».
4. All photography or additional comments must be clearly differentiated with the text of origin.